

Fluid purifier systems and  
oil service equipment

**EATON**

*Powering Business Worldwide*

**Eaton** combines sales, engineering, manufacturing, customer service and technical sales support into one focused business provide customers with optimum filtration solutions.

Eaton is continually striving for improvement, with integrity as an underlying business strategy that forms the trademark of all its products and services. Eaton is one of the leading manufacturers of products and solutions for filtration combining measurement, diagnostic and analysis technology, as well as more than 4,000 hydraulic filter elements and corresponding filter housings.

### **Filtration of cooling, hydraulic and lubricant fluids**

- Stationary off-line filter units  
**US series**
- Mobile off-line filter units  
**UM series**
- Mobile off-line fluid cleaning systems  
**IFPM series**



**Improve the reliability of the entire system's equipment and prolong fluid service life by reducing solid and water contamination, maintaining lubricity and slowing fluid aging.**

### Oil service equipment for hydraulic and lubrication systems

An in-line filter is generally sufficient for use in hydraulic and lubrication systems. When filling for the first time, changing the oil, flushing, or for machines with a discontinuous volume flow, Eaton recommends additional off-line filtration.

To ensure optimum operation, flushing must be performed before initial start up in stationary and mobile hydraulic and lubrication systems.

Eaton's oil treatment systems simplify offline filtration and help save costs new oil, maintenance and replacing components.

### Features of off-line filter units

- Reliable and simple off-line filtration
- Reinforces existing operating in-line filter
- Improves cleanliness classes
- Longer service life of system components and operating fluids
- Compact design saves space and adapts to your operation
- High-quality filter elements with high dirt holding capacity
- Filter elements can be replaced without tools or system downtime
- Safety valves permit unattended operation
- Uninterrupted filtration during tank filling
- Optional use of water-absorbing filter elements
- Additional clogging indicators available upon request

### US series stationary off-line filter units

The stationary filter units in the US series are used for the fine filtration, filling or flushing of hydraulic systems. The filter units are equipped with a gear pump driven by an electric motor. They are available for various volume flow rates, in different sizes, and with different micron ratings for the required fluid cleanliness.

### UM series mobile offline filter units

The mobile filter units in the UM series combine the convenience of the US filter units with mobile oil treatment in hydraulic and lubrication systems.

The filter units in the UMP series have a pneumatic double diaphragm pump instead of an electronic gear pump, and are suitable for explosion proof applications (Ex II 2 G/D c IIA T5).

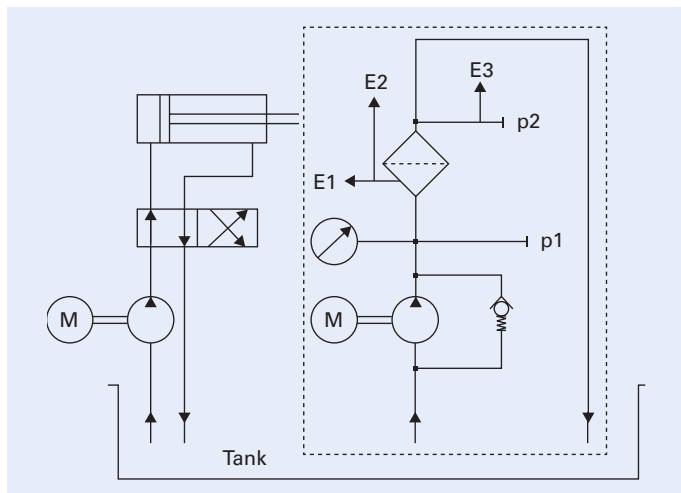

During off-line filtration, the filter operates in a cycle that is separate from the main system. By separating the systems, off-line filtration can take place independently of the system's running time until the desired fluid cleanliness is reached.



### Removal of water, gases and solid contaminants using fully automated compact systems.

Eaton fluid purifier systems remove free, emulsified and dissolved water, free and dissolved gases, and solid contaminants. They have been developed for different viscosity ranges, from transformer to heavy gear lubricating oils. The selection of the micron rating used depends on the required fluid purity. The mobile fluid cleaning systems in the IFPM series are available in two standard sizes with flow rates of 30 l/min and 70 l/min.

#### Effects of water contamination

Water is one of the most frequently occurring contaminants and is second only to particulate contamination as a destructive foreign substance in a system. Some of the problems and damage water contamination can cause include:

- Shortened service life of the fluid
- Reduced performance of the lubricating fluid
- Heavy wear to the components
- Loss of polarizing additives
- Rust
- Increased conductivity

#### IFPM fluid cleaning system technology

Vacuum dehydration with air as inert gas is the most effective water removal method for fluid cleaning systems. This method combines high water separation rates with an efficient use of energy, and allows the drying process to take place even below the saturation point of the prepared fluid. By contrast, conventional vacuum evaporation only brings the water content of the fluid to the same level as that of the water vapor in the surrounding atmosphere.

The IFPM fluid purifier systems are fully automated, PLC-controlled compact enough for use in confined areas. The WSPS 05 sensor permanently monitors the water saturation in a purified fluid. The VS5 electronic contamination sensor provides the optimal use and maintenance scheduling of the particle removal filter element.

#### Operating principle

- The contaminated fluid is drawn into the fluid cleaning system using a vacuum
- Fluid reaches the vacuum chamber through a two-port magnetic valve
- The fluid passes a heater, which raises the temperature in order to increase the water removal process
- The dispersion material in the vacuum chamber increases the fluid's evaporation surface area
- The vacuum decreases the water evaporation temperature, converting free water and water dissolved in the fluid into steam
- Ambient air enters through a ventilation filter and passes through the fluid against the direction of flow, acting as a carrier medium for the steam produced
- The humid air enters a vacuum pump and released into the atmosphere using an oil mist separator

IFPM 33



IFPM 73





Web-enabled control unit with touch panel and USB interface

### Factors affecting system efficiency

The processing time required to reach an acceptable water content level is primarily dependent on the fluid type. Other factors affecting the speed of the drying process are listed in the following table.

Parameter	Water removal rate
Temperature:	Greatly increased
Vacuum:	Increased
Initial water content:	Increased
Additives:	Reduced
Flow rates:	Increased

Chart of water content over time for various fluids

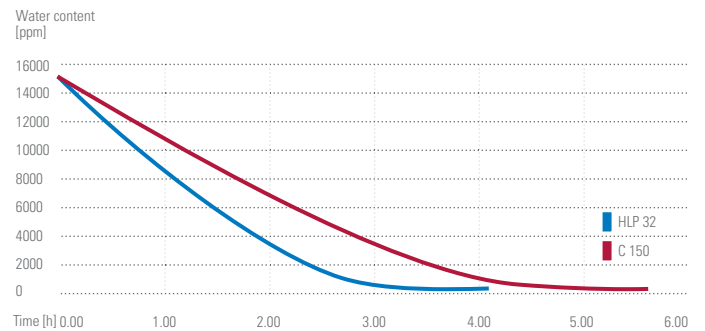

Technical Data	IFPM 33	IFPM 73
<b>Operating parameters:</b>		
Power supply options:	380 to 415 V AC/50/60 Hz/8.1 A/4.7 kW or 440 to 480 V AC/60 Hz/7.6 A/5.2 kW	380 to 415 V AC/50/60 Hz/15.6 A/9.3 kW or 440 to 480 V AC/60 Hz/14.4 A/10.1 kW
Protection class:	IP 54	IP 54
Max. intake pressure:	≤ 0.2 bar	≤ 0.2 bar
Viscosity:	12 to 700 mm <sup>2</sup> /s	12 to 700 mm <sup>2</sup> /s
Fluid temperature:	10 to 80°C	10 to 80°C
Ambient temperature:	0 to 40°C	0 to 40°C
Intake connector:	SAE flange 1 1/4" (3000 PSI)	SAE flange 1 1/4" (3000 PSI)
Outlet connector:	SAE flange 1 1/4" (3000 PSI)	SAE flange 1 1/4" (3000 PSI)
Volume flow*:	29.1 l/min	71.8 l/min
Water removal rate**:	22 l/day	54 l/day
<b>Measurement parameters:</b>		
Water saturation:	0 to 100%	0 to 100%
Temperature:	-25 to 100°C	-25 to 100°C
Pressure (vacuum chamber):	-1 to 0 bar (relative)	-1 to 0 bar (relative)
Filter contamination:	50 to 100%	50 to 100%

\* With a fluid viscosity of 32 mm<sup>2</sup>/s \*\* Free water at 60°C and 32 mm<sup>2</sup>/s

## FLUID MANAGEMENT PRODUCTS

### Off-line filter units

#### Stationary

US 10  
US 16  
US 20  
US 21  
US 22  
US 40  
US 80  
US 160  
US 320  
US 321  
US 640  
US 960

#### Mobile

UM 20  
UM 40  
UM 80  
UM 125  
UFM 15  
  
With pneumatic  
double diaphragm  
pumps:  
UMP 20  
UMP 40

### Off-line fluid cleaning systems

#### Mobile

IFPM 33  
IFPM 73

**North America**  
44 Apple Street  
Tinton Falls, NJ 07724  
Toll Free: 800 656-3344  
(North America only)  
Tel: +1 732 212-4700

**Greater China**  
No. 7, Lane 280,  
Linhong Road  
Changning District, 200335  
Shanghai, P.R. China  
Tel: +86 21 2899-3687

**Europe/Africa/Middle East**  
Auf der Heide 2  
53947 Nettersheim, Germany  
Tel: +49 2486 809-0  
  
Friedensstraße 41  
68804 Altlußheim, Germany  
Tel: +49 6205 2094-0

**Asia-Pacific**  
100G Pasir Panjang Road  
#07-08 Interlocal Centre  
Singapore 118523  
Tel: +65 6825-1620

An den Nahewiesen 24  
55450 Langenlonsheim, Germany  
Tel: +49 6704 204-0

**For more information, please  
email us at [filtration@eaton.com](mailto:filtration@eaton.com)  
or visit [www.eaton.com/filtration](http://www.eaton.com/filtration)**

© 2023 Eaton. All rights reserved. All trademarks and registered trademarks are the property of their respective owners. All information and recommendations appearing in this brochure concerning the use of products described herein are based on tests believed to be reliable. However, it is the user's responsibility to determine the suitability for his own use of such products. Since the actual use by others is beyond our control, no guarantee, expressed or implied, is made by Eaton as to the effects of such use or the results to be obtained. Eaton assumes no liability arising out of the use by others of such products. Nor is the information herein to be construed as absolutely complete, since additional information may be necessary or desirable when particular or exceptional conditions or circumstances exist or because of applicable laws or government regulations.

EN  
EFINHDLEU  
04-2023