

# PRESSURE FILTER, manifold mounted

## Series HPP 601-1351 4568 PSI

Sheet No.  
**1470 M**

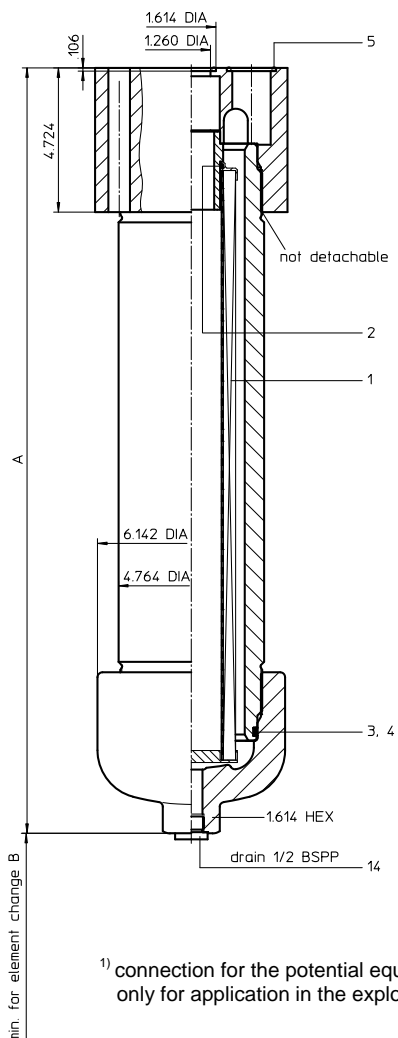
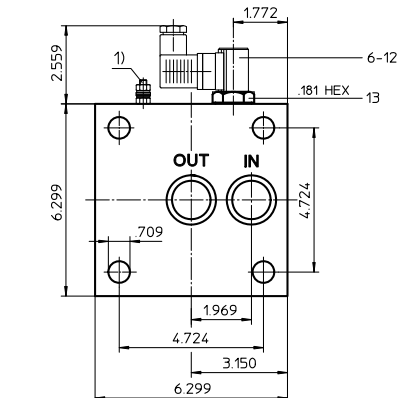

<sup>1)</sup> connection for the potential equalisation, only for application in the explosive area

## 2. Dimensions: inch

type	HPP 601	HPP 901	HPP 1351
connection	1 1/4"	1 1/4"	1 1/4"
A	19.17	25.07	34.84
B	12.20	18.11	27.95
weight lbs.	86	101	128
volume tank	.55 Gal.	.82 Gal.	1.21 Gal.

## 1. Type index:

### 1.1. Complete filter: (ordering example)

**HPP. 901. 10VG. HR. E. P. -. P. 6. -. -. AE**

1	2	3	4	5	6	7	8	9	10	11	12
---	---	---	---	---	---	---	---	---	----	----	----

#### 1 series:

HPP = pressure filter, manifold mounted

#### 2 nominal size: 601, 901, 1351

#### 3 filter-material and filter-fineness:

80 G = 80  $\mu\text{m}$ , 40 G = 40  $\mu\text{m}$ , 25 G = 25  $\mu\text{m}$  stainless steel wire mesh  
 25 VG = 20  $\mu\text{m}_{(c)}$ , 16 VG = 15  $\mu\text{m}_{(c)}$ , 10 VG = 10  $\mu\text{m}_{(c)}$ ,  
 6 VG = 7  $\mu\text{m}_{(c)}$ , 3 VG = 5  $\mu\text{m}_{(c)}$  Interpor fleece (glass fiber)

#### 4 resistance of pressure difference for filter element:

30 =  $\Delta p$  435 PSI

HR =  $\Delta p$  2320 PSI (rupture strength  $\Delta p$  3625 PSI)

#### 5 filter element design:

E = single-end open

#### 6 sealing material:

P = Nitrile (NBR)

V = Viton (FPM)

#### 7 filter element specification: (see catalog)

- = standard

VA = stainless steel

IS06 = see sheet-no. 31601

#### 8 connection:

P = manifold mounted

#### 9 connection size:

6 = 1 1/4"

#### 10 filter housing specification: (see catalog)

- = standard

IS06 = see sheet-no. 31605

#### 11 internal valve:

- = without

S1 = with by-pass valve  $\Delta p$  51 PSI

S2 = with by-pass valve  $\Delta p$  102 PSI

R = reversing valve,  $Q \leq 122.94$  GPM

#### 12 clogging indicator or clogging sensor:

- = without

AOR = visual, see sheet-no. 1606

AOC = visual, see sheet-no. 1606

AE = visual-electrical, see sheet-no. 1615

VS1 = electronical, see sheet-no. 1617

VS2 = electronical, see sheet-no. 1618

### 1.2. Filter element: (ordering example)

**01E. 900. 10VG. HR. E. P. -**

1	2	3	4	5	6	7
---	---	---	---	---	---	---

#### 1 series:

01E. = filter element according to company standard

#### 2 nominal size: 600, 900, 1350

#### 3 - 7 see type index-complete filter

EDV 07/14

Changes of measures and design are subject to alteration!

### 3. Spare parts:

item	qty.	designation	dimension			article-no.	
			HPP 601	HPP 901	HPP 1351		
1	1	filter element	01E.600	01E.900	01E.1350		
2	1	O-ring		48 x 3		304357 (NBR)	304404 (FPM)
3	1	O-ring		98 x 4		301914 (NBR)	304765 (FPM)
4	1	support ring		110 x 3,5 x 2		304802	
5	2	O-ring		34 x 3,5		304338 (NBR)	304730 (FPM)
6	1	clogging indicator, visual		AOR or AOC		see sheet no. 1606	
7	1	clogging indicator, visual-electrical		AE		see sheet no. 1615	
8	1	clogging sensor, electronic		VS1		see sheet no. 1617	
9	1	clogging sensor, electronic		VS2		see sheet no. 1618	
10	1	O-ring		15 x 1,5		315357 (NBR)	315427 (FPM)
11	1	O-ring		22 x 2		304708 (NBR)	304721 (FPM)
12	1	O-ring		14 x 2		304342 (NBR)	304722 (FPM)
13	1	screw plug		20913-4		309817	
14	1	screw plug		½ BSPP		304678	

item 13 execution only without clogging indicator or clogging sensor

### 4. Description:

The pressure filters of the series HPP 601-1351 are suitable for a working pressure up to 4568 PSI. The pressure peaks are absorbed by a sufficient margin of safety. The HPP-filters are flange mounted to the hydraulic system. The filter element consists of star-shaped, pleated filter material which is supported on the inside by a perforated core tube and is bonded to the end caps with a high-quality adhesive. The flow direction is from outside to the inside. Filter elements are available down to 5  $\mu\text{m}_{(c)}$ . Internormen Product Line filter elements are known as elements with a high intrinsic stability and an excellent filtration capability, a high dirt-retaining capacity and a long service life. Internormen product Line filter are suitable for all petroleum based fluids, HW-emulsions, most synthetic hydraulic fluids and lubrication oils. Internormen Product Line filter elements are available up to a pressure difference resistance of  $\Delta p$  2320 PSI and a rupture strength of  $\Delta p$  3625 PSI. The internal valves are integrated into the centering pivot for the filter element. After reaching the opening pressure the by-pass valve causes that an unfiltered partial flow passes the filter. With the reverse valve a protection of the filter element is given when having a reverse flow inside the filter. The reverse flow will not be filtered.

### 5. Technical data:

temperature range:	+14°F to +176°F (for a short time +212°F)
operating medium:	mineral oil, other media on request
max. operating pressure:	4568 PSI
test pressure:	6525 PSI
connection system:	manifold mounted
housing material:	C-steel; EN-GJS-400-18-LT
sealing material:	Nitrile (NBR) or Viton (FPM), other materials on request
installation position:	vertical

Classified under the Pressure Equipment Directive 97/23/EC for mineral oil (fluid group 2), Article 3, Para. 3.  
Classified under ATEX Directive 94/9/EC according to specific application (see questionnaire sheet-no. 34279-4).

### 6. Symbols:

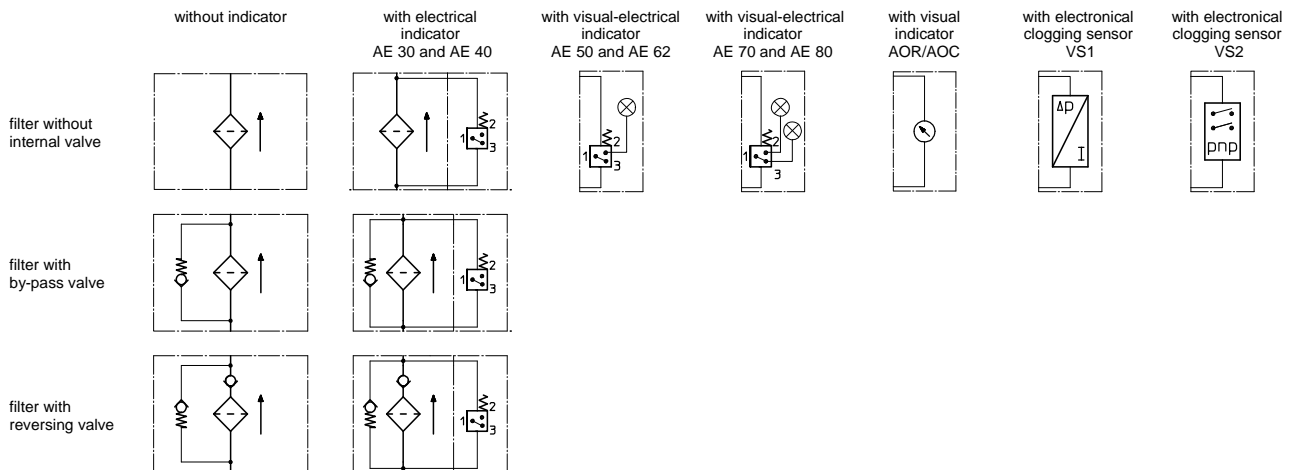

**7. Pressure drop flow curves:** Precise flow rates see 'Interactive Product Specifier', respectively  $\Delta p$ -curves; depending on filter fineness and viscosity.

### 8. Test methods:

Filter elements are tested according to the following ISO standards:

ISO 2941	Verification of collapse/burst resistance
ISO 2942	Verification of fabrication integrity
ISO 2943	Verification of material compatibility with fluids
ISO 3723	Method for end load test
ISO 3724	Verification of flow fatigue characteristics
ISO 3968	Evaluation of pressure drop versus flow characteristics
ISO 16889	Multi-pass method for evaluating filtration performance